

FD-C Series



Circular Single Blade Externally Resettable Fire Damper

- Conforms to fire damper product standard EN15650
- ES classified fire dampers with reduced smoke leakage characteristics EN 13501-3
- Aerodynamically Air Control tested to BS EN 1751
- Tested installation methods in differing supporting constructions (BS EN 1366-2)
- Integrated volume control capability
- Replaceable fusible link from outside of the ductwork
- Commissioning friendly
- External blade position indicator
- Damper casing sizes and tolerances conform to BS EN 1506



A brand of
MAICO



MANUFACTURERS OF AIR, FIRE AND SMOKE CONTROL SYSTEMS

FD-C Series

Single Blade Circular Fire Dampers - Introduction

The FD-C Series

The FD-C Manual Operation Single Blade Fire Damper with volume control facility has been designed specifically for installations where space is at a premium.

The testing and resetting of the damper and thermal fuse external of the duct allows for ease of commissioning and maintenance.

NB: Access panels may be required to comply with DW145 G.3.1.5.

The installation plate, with its engineered installation perforations, acts as a template to allow the marking of the fixing positions on the surface of the structure to which the plate will be affixed, allowing for a quick and efficient install.



Introduction

What is a fire damper and why might they be needed? The FD-C Series Single Blade Circular Fire Damper is designed to stop the spread of fire through ducts, walls and floors.

The product range has many features and options to meet the requirements of specifiers, contractors, local and national authorities. Dampers are available to suit both low and medium velocity applications.

What are the 'E' and 'ES' classifications?

To achieve the classifications to EN13501-3, fire dampers and fire and smoke dampers shall meet product standard 15650 be tested to EN1366-2 where a 300Pa pressure difference is applied across the damper. During the fire test period, the integrity of the seal between the damper and the structure shall not have any gaps larger than 6mm x 150mm. There shall not be any sustained flaming. The largest size of damper to be manufactured for sale as a single section shall be fire tested.

E = Integrity

The maximum leakage permissible at 300Pa corrected to 20°C is 360m³/hr/m² (100 l/s/m²) throughout the fire test period.

ES = Integrity with Smoke Leakage Performance

The maximum leakage permissible at 300Pa corrected to 20°C is 200m³/hr/m² (55.5 l/s/m²) at ambient prior to the fire test and throughout the fire test period. In addition, for the ES classification to be attained, the smallest damper must also meet the 200m³/hr/m² maximum ambient leakage with a 300Pa pressure across the damper. (This is equivalent to just 0.55 l/s on a 100 dia. damper).

Fire dampers should be installed as tested.

FD-C Features and Benefits

- Tested and certified installation variants of the FD-C are available for dry walls, masonry walls, flexible fire curtain and concrete floors.
- All BSB tested installation methods give at least a E60 classification. see DoP and installation drawing for full details

Leakage Classification

Blade leakage classification is given numerically 1 - 4 and case leakage classification is given using capital letters A - C of EN1751 (sections C.2 and C.3).

The FD-C series damper meets Class 3 blade leakage section C.2 refers and Class C case leakage section C.3 of the EN1751 standard, section C.2 refers.

Normal operating conditions - not exceeding 1100Pa, Classes A, B & C of DW 144 2016 Specification will apply.

The FD-C Series Range

The BSB FD-C series is available in the following case diameters:

FD-C100 - 100mm diameter	FD-C200 - 200mm diameter
FD-C125 - 125mm diameter	FD-C250 - 250mm diameter
FD-C150 - 150mm diameter	FD-C300 - 300mm diameter
FD-C160 - 160mm diameter	FD-C315 - 315mm diameter

Testing and Conformities

CE marked to EN1366-2

See installation details for full details.

Tested and achieved classification to:

ES Classification (BS EN 1366-2/BS EN 13501-3)

Classification	Supporting Construction	Drawing
E 120 (ho i←o) S	Masonry Floor with Batt Infill	FD-C M7
E 120 (ve i↔o) S	Masonry Wall with Batt Infill	FD-C M8
E 60 (ve i↔o) S	Drywall Partition	FD-C M9
E 90 (ve i↔o) S	Drywall Partition	FD-C M9
E 120 (ve i↔o) S	Masonry Wall	FD-C M9
E 120 (ho i←o) S	Masonry Floor	FD-C M10
E 120 (ho i←o) S	Masonry Floor	FD-C M11
E 60 (ve i↔o) S	Fire Curtain	FD-C M14
Refer to CE-DoP-FD-C for full details		

FD-C Blade leakage (BS EN 1751)

- Class 2

FD-C Case leakage

- Eurovent 2.2 Class C

Corrosion testing (BRE)

- Tested and satisfies LPS1162
- Complying with test method BS EN 60068-2-11

Typical Tender/Specification Text

The BSB FD-C Fire Damper shall pass the test requirements stated in EN 1366-2 and conforms to the product standard for fire dampers EN15650. For maintenance of the integrity of compartmentation the fire damper shall have an E classification to EN 13501-3.

The damper shall have an ES classification complying with EN1366-2 and EN 13501-3 and have a minimum ES60 rating.

Damper casings shall conform to BS EN 1506.

For the protection of escape routes and areas with sleeping risk, the FSD-C fire/smoke damper should be used. Please refer Approved Document B (ADB).

The single blade layered design shall be held open against a torsion spring that is released via a fusible link having an alloy component that melts at 72°C allowing the spring mechanism to close the damper.

The damper assembly and fusible link shall be safely tested and released closed externally to the damper without the need for specialist tools or access panels. NB: Access panels may be required to comply with DW145 G.3.1.5.

The fire damper body shall be stitch welded to meet the air tightness test requirements of HVCA specification. Normal operating conditions - not exceeding 1000Pa, Classes A & B of DW 144 2016 Specification will apply.

The closed blade shall meet the air tightness test requirement of BS EN 1751 Class 2.

The BSB FD-C fire damper shall have a tested installation method that matches the requirement of the supporting construction. DW145 Method 4 Blockwork Walls, Dry Walls and Concrete Floors refers.

Weight Chart (approx.)

Nom. Dia. (mm)	Kg
100	1.2
125	1.6
150	2.0
160	2.1
200	2.8
250	4.0
300	5.0
315	5.1

Damper Free Area (fully open)

Model	Free Area	Model	Free Area
FD-C100	64%	FD-C200	85%
FD-C125	73%	FD-C250	88%
FD-C150	79%	FD-C300	91%
FD-C160	81%	FD-C315	91%

Micro Switch

The factory fitted micro switch to provide remote indication of the damper blade status. The micro switch is fitted on the opposite side to the operating handle where a purpose designed cam fitted to the protruding blade operating spindle allows the release of the micro switch actuating lever, allowing the snap action contacts 1NO + 1NC to change state.

Wiring connections are made via M3, 5 terminal screw fixings.

Mechanical life: 1 million cycles

Complies with EN60204 and EN292 standards

Electrical data:

Thermal current (Ith): 16A
Rated insulation voltage: 250VAC 300VDC
Protection against short circuits: fuse 10A 500V type gG

Utilisation categories:

Alternate current: AC15 (50 ... 60Hz)
Ue (V) 250
Ie (A) 5
Direct current: DC13
Ue (V) 24 125 250
Ie (A) 4 1,1 0,4

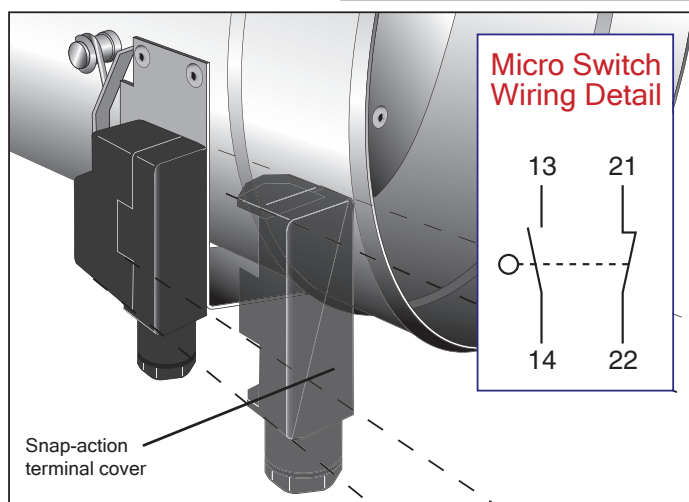

FD-C Series Dampers - Testing and Maintenance

FD-C Series dampers are designed for normal dry filtered air systems. A programme of planned inspections should be carried out to include full operational checks, correct interface with, and function of, any control systems, cleaning and light lubrication.

As a guide, this should take place on a maximum of six months intervals.

Reference should be made to BS 9999 for more information.

Records of damper installation and position shall be kept. Records of the condition of the dampers and their functionality/repair etc should be kept as these products come under the requirements of the Regulatory Reform (Fire Safety) Order (RRFSO).

These inspection and maintenance programmes may need to be repeated more regularly if the dampers are exposed to inclement/dusty conditions or fresh air intakes and the frequency of such checks should be reviewed based on site experience.

Storage

Dampers received on site should be stored in a purpose made storage area, where they can be protected from moisture, dust and impact damage until required.

FD-C Series

Single Blade Circular Fire Dampers - Product Specification

Case

Galvanised mild steel to BS EN 10346 DX 51D Z275 0.8±0.1mm
Damper casing conforms to BS EN 1506.

Fusible Link

Fusible link externally replaceable rated at 72°C has been designed to eliminate linear creep of the solder joint. The thermal link is screwed into position via the 12.5mm diameter brass holder activating the locking assembly from outside the case in any position from fully open to fully closed, allowing air balance during the commissioning of the ducted system.

Handle

The handle is an 8mm dia. preformed 400 series ferritic stainless steel rod that allows the setting of the damper to any set point or fully open position. The blade angle is shown via the graduated affixed label.

Installation Plate

The installation plate allows the damper to be fixed into place from one side only with no infill material required on the non-handle side. Use either of the two appropriate 5mm dia. corner fixing holes and all of the 5mm dia. mid span fixing holes to secure the plate into position.

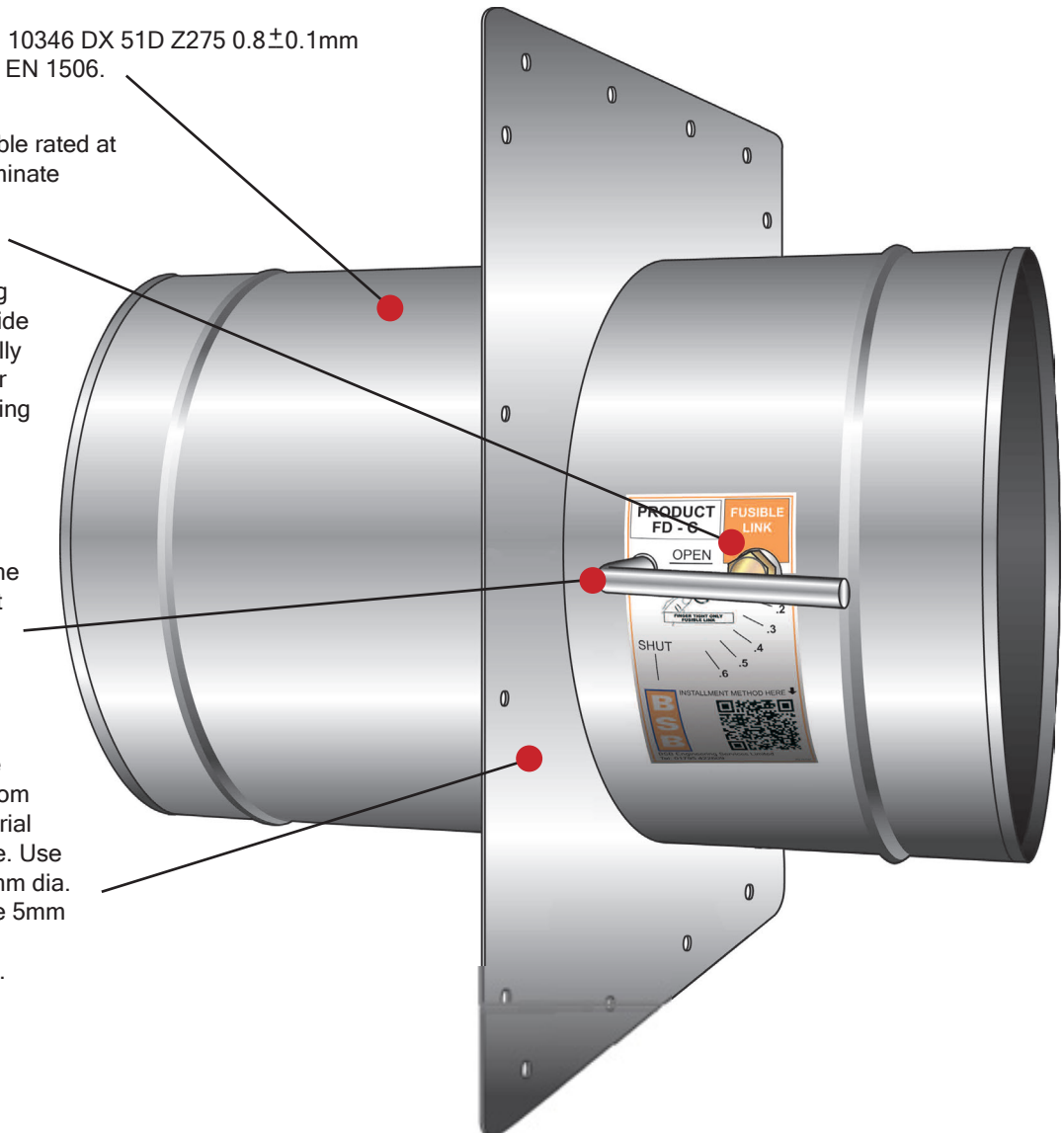

Blade Seal (patented)

Layered glass woven sheets and central intumescent disc to a patented design that allows the blade assembly to be of minimal thickness, thus minimising pressure loss with fully open damper, and an effective seal when fully closed to comply with EN 1366-2 achieving ES classification.

Blade

Galvanised 1.2mm one piece circular steel discs either side of the patented seal design providing a 5mm thick assembly affixed by blade brackets to the reset handle.

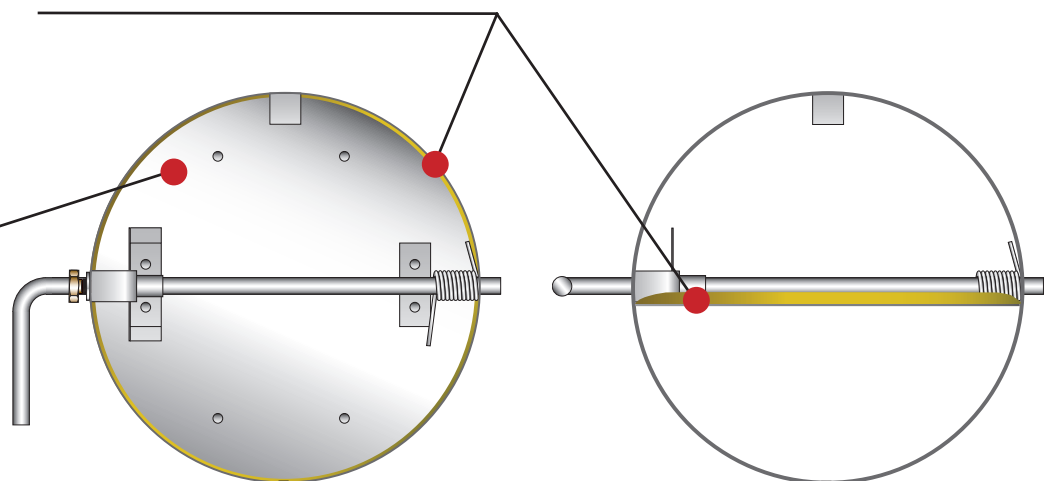

Blade Closed

Blade Open

The FD-C Series

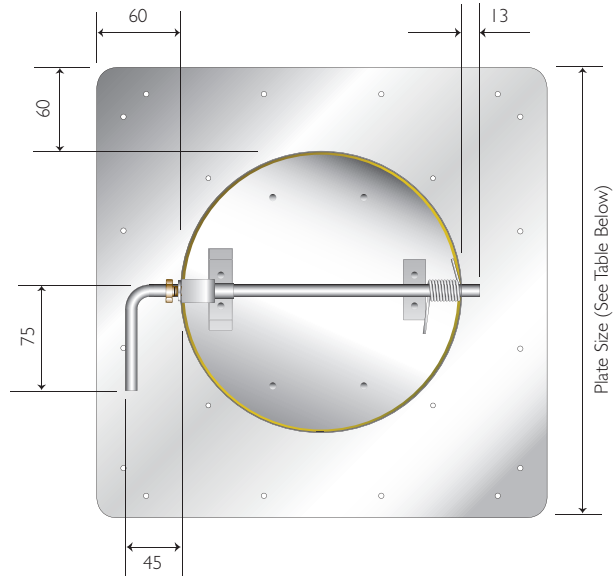
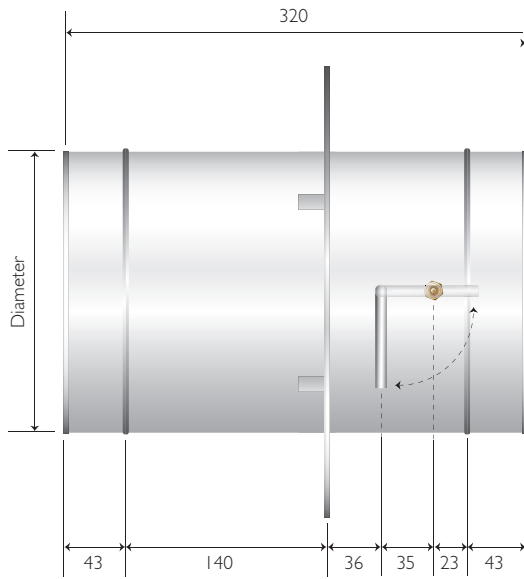

Installation Plates

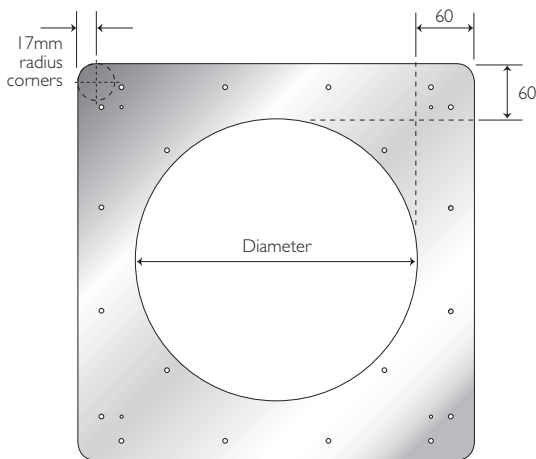

Model	Dia. (mm)	Square Plate Size (mm)
FD-C100	100	220
FD-C125	125	245
FD-C150	150	270
FD-C160	160	280
FD-C200	200	320
FD-C250	250	370
FD-C300	300	420
FD-C315	315	435

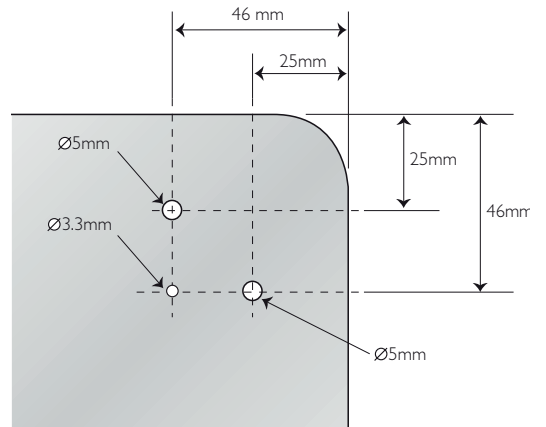

NB: Use either of the two appropriate 5mm dia. corner fixing holes and all of the 5mm dia. mid span fixing holes to secure the plate to the steelwork within the dry wall/into masonry wall/floor.

Cleats (Not FC)

Rotatable cleats are available as an optional accessory where requested and will be provided factory fitted as shown right.

The FD-C series damper must be installed as per BSB installation, operating and maintenance document to comply with CE marking.

The use of cleats as the sole installation/support method will not comply with CE marking rules.

Where cleats are requested to be fitted and local authority approval has been given, the drop rod system will be the responsibility of others.

Fixing Kit

Fixing cleat (4) kits are available for retro fixing, please refer to the sales office.

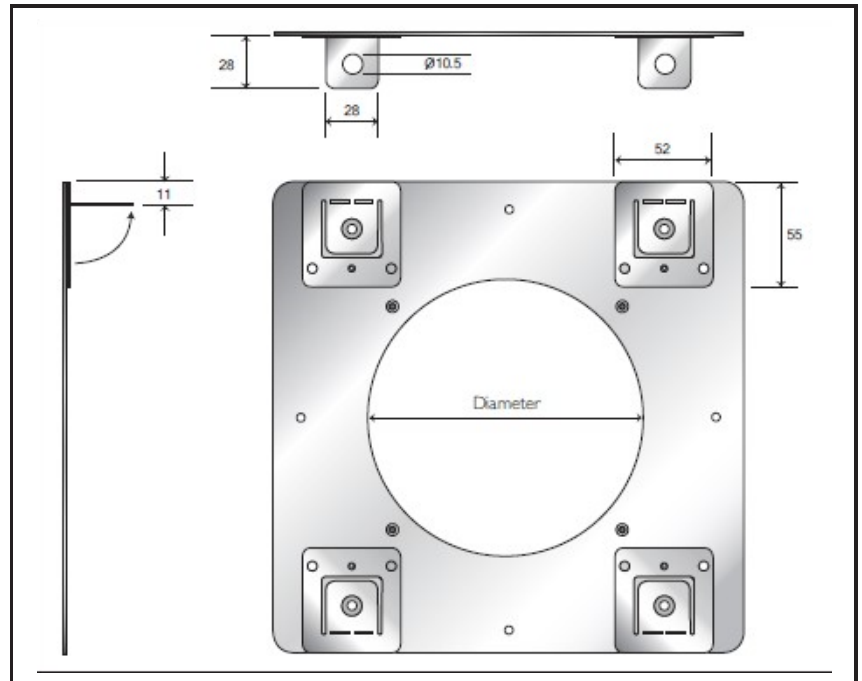

Clamp Plate Flexible Fire Curtain

FD-C-FC

In addition to the installation plate secured to the damper, the FD-C-FC damper has an additional clamp plate for installation.

The clamp plate has thread forms to receive the safety self-tapping screws through the fire curtain material.

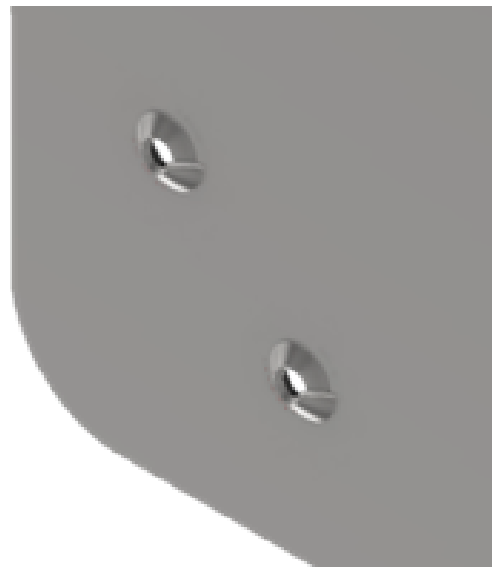

FD-C Series

Single Blade Circular Fire Dampers - Rotatable Cleats

Rotatable Easy Bend Cleats (Not FC)

The optional Rotatable Cleat Easy Fix System will be supplied factory fitted to the FD-C Series dampers.

The installation plate should be fitted to the fire separation barrier to ensure test conformity is maintained. The Easy Bend Cleat is available factory fitted four per plate. The cleats should only be used where the fire separation element is not yet in place, offering a temporary installation support. The cleats must not be the sole independent method of supporting the fire damper.

The cleats can easily be bent out using a flat head screwdriver. Supporting drop rods are used in the normal way.

The cleats can be rotated through 90 degrees to suit handle position where the damper requires to be installed with the handle of either left, right, top or bottom giving full flexibility during installation.

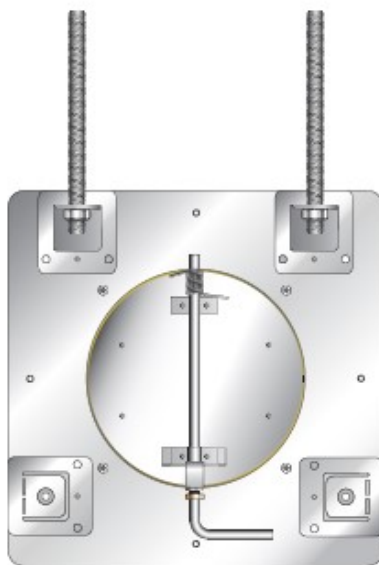
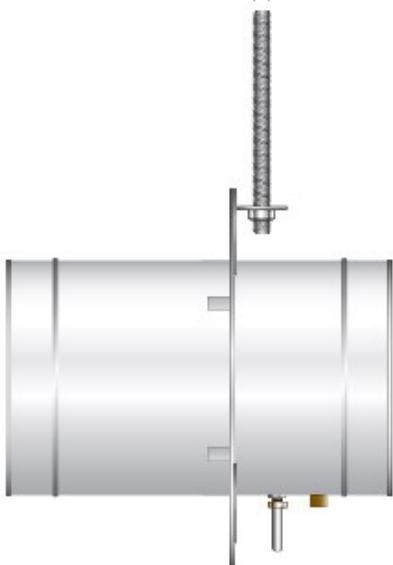
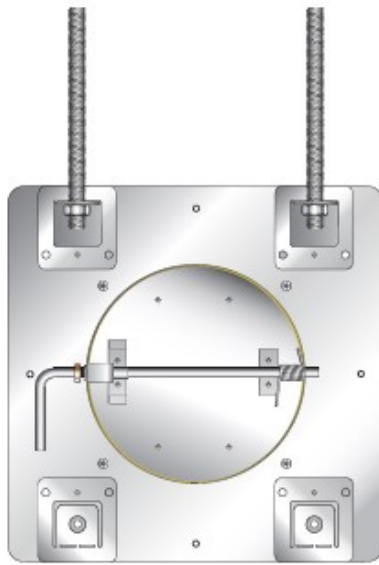
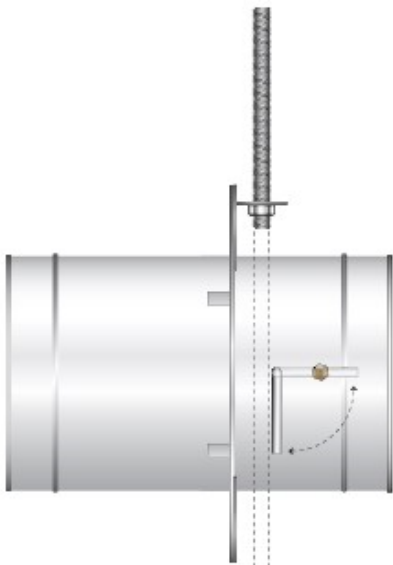
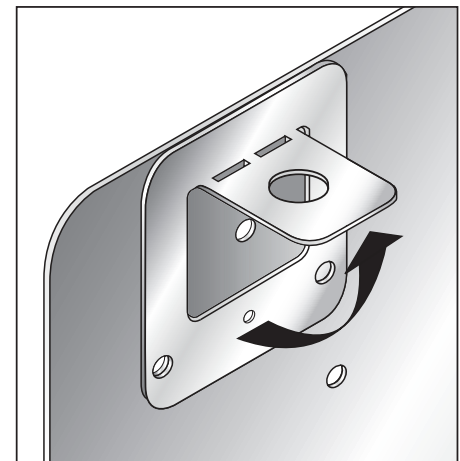
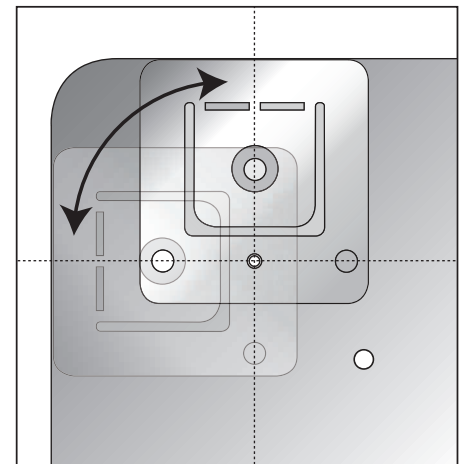
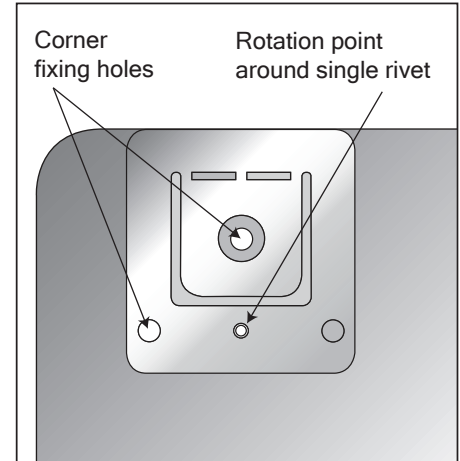

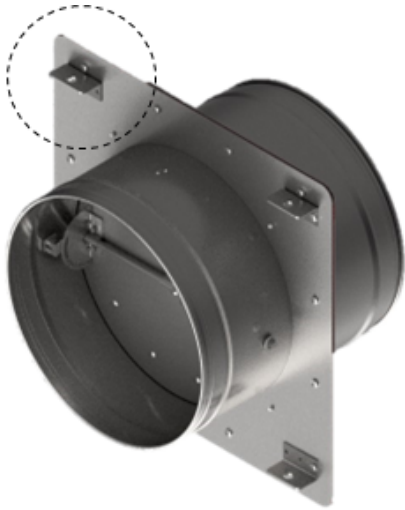

FD-C-FC Cleats

These cleats are supplied factory fitted for the FD-FC damper. These cleats are specific only to the Fire Curtain installation type.

Performance Data

Pressure Drop Graph

100mm diameter. Free area = 64%
Velocity range 0 to 10 m/s

- 67.5° from open
- 45° from open
- 22.5° from open
- Fully open

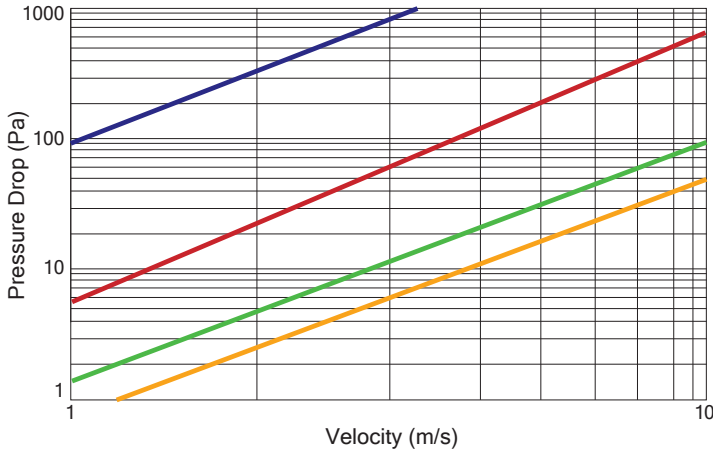

Pressure Drop Graph

200mm diameter. Free area = 85%
Velocity range 0 to 10 m/s

- 67.5° from open
- 45° from open
- 22.5° from open
- Fully open

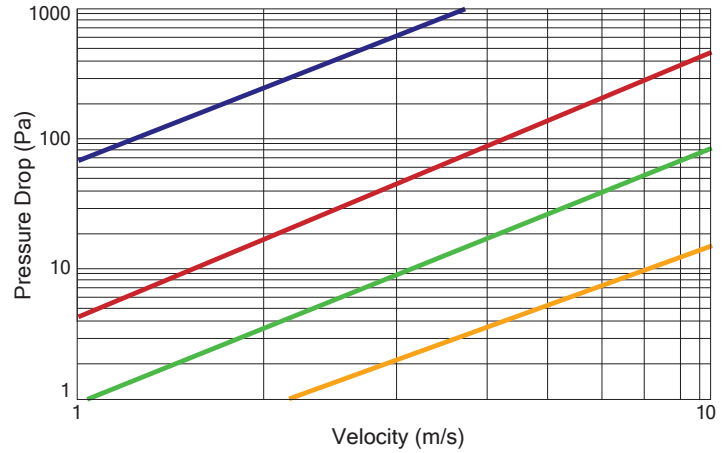

Pressure Drop Graph

300mm diameter. Free area = 91%
Velocity range 0 to 10 m/s

- 67.5° from open
- 45° from open
- 22.5° from open
- Fully open

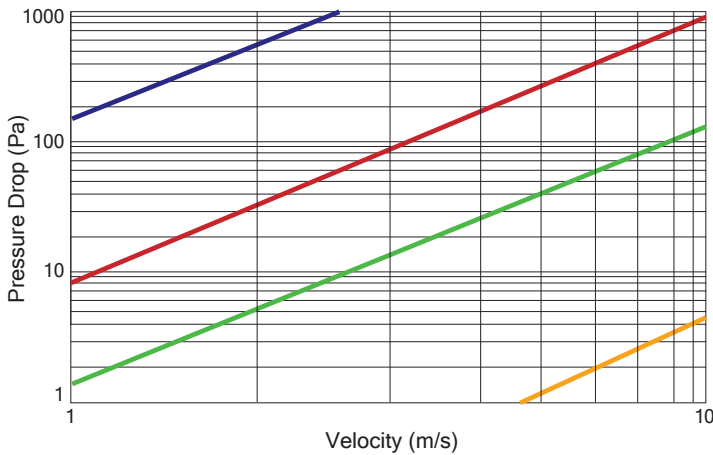

Case Leakage Curve

Model FD-C100 to BS EN 1751

Shaded area - above 1000Pa for system pressure test only.
Normal operation maximum 1000Pa

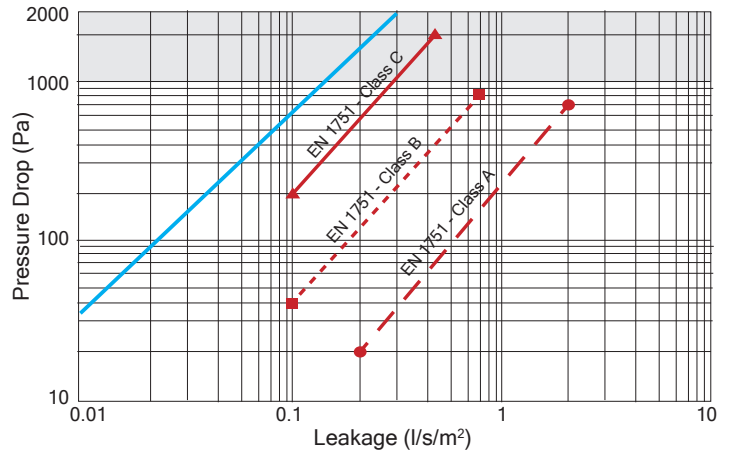

Blade Leakage Graph

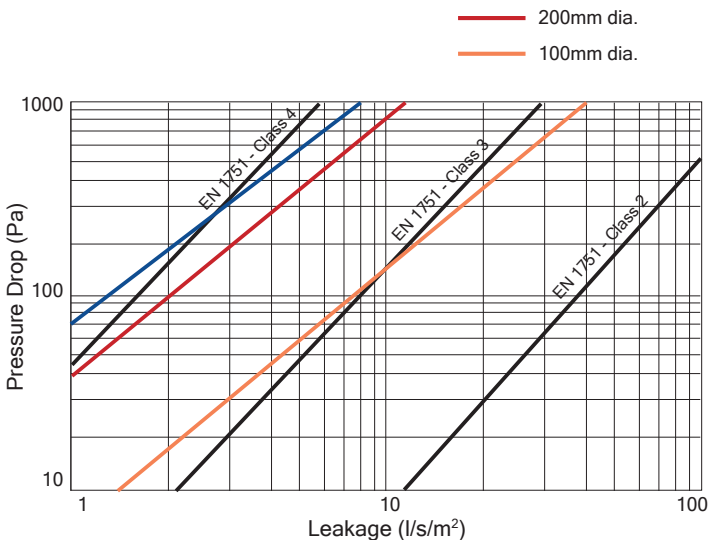

Ambient Case Leakage

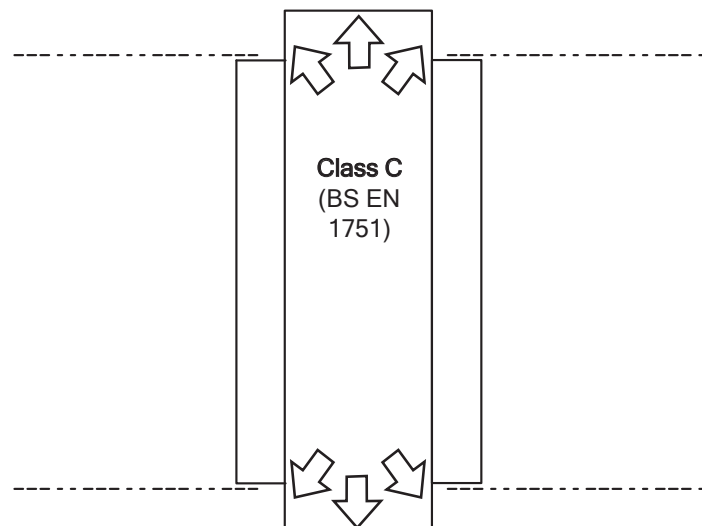

INSTALLATION METHOD FD-C MASONRY FLOOR BATT

PLEASE REFER TO INSTALLATION, OPERATING AND MAINTENANCE DOCUMENT FOR DETAILED INFORMATION.
I, O & M AVAILABLE FROM QR CODE IN FOOTER.
USE BREAK-AWAY JOINTS (ALUMINIUM RIVETS) ON CONNECTING DUCTWORK.
CONNECTING DUCTWORK HAS BEEN OMITTED FOR CLARITY.

FD-C M7-r1

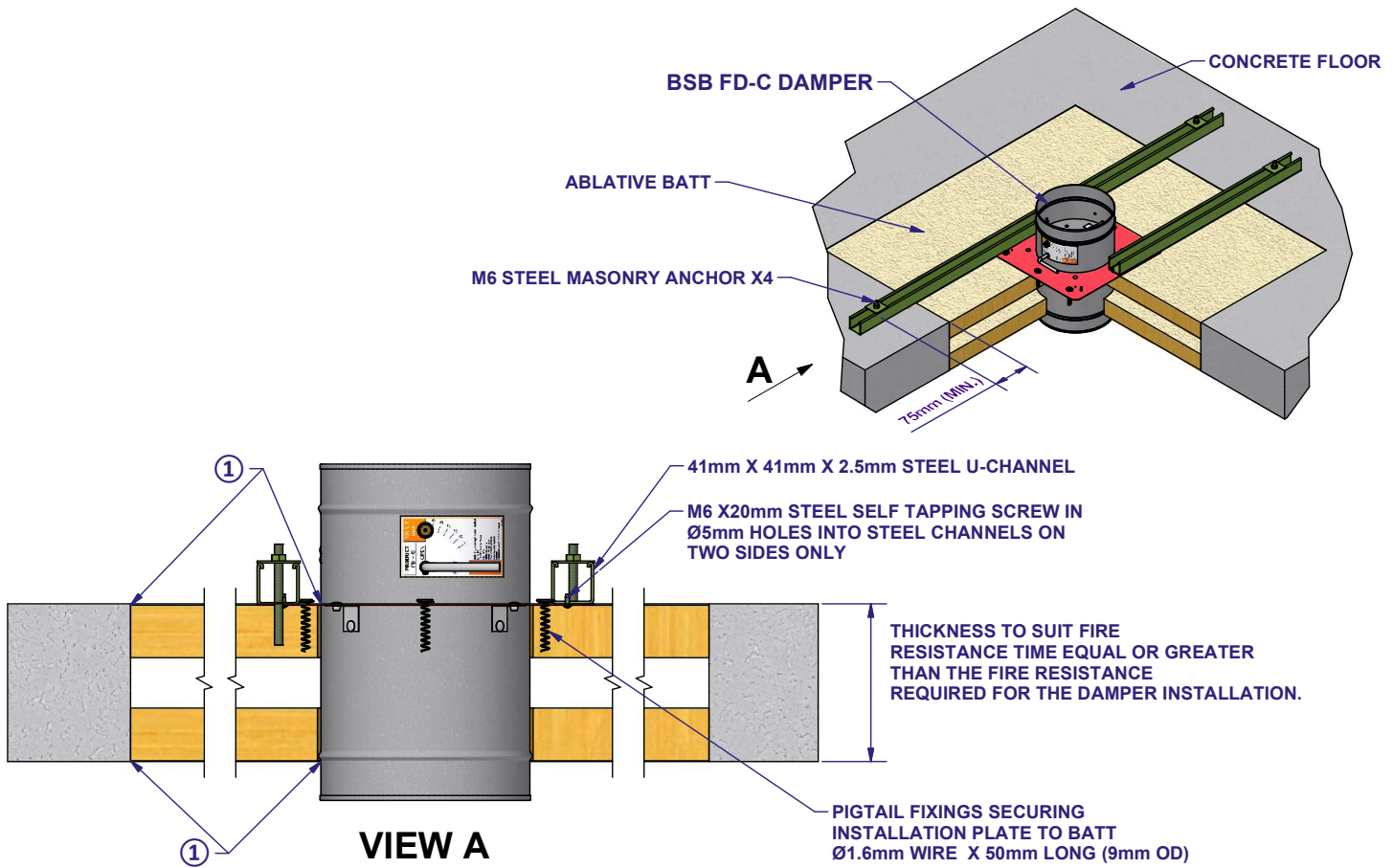

CLASSIFICATION		
MINIMUM CONSTRUCTION	CASE / BLADE MATERIAL	MAXIMUM LEVEL AND / OR CLASSES
150mm Thick Masonry Density 580kg/m ³ 2 x Layers of 50mm Ablative Coated Batt Density 140kg/m ³	Galvanised Steel	E 120 (ho i-o) S

① 10-15mm BEAD OF INTUMESCENT MASTIC AROUND PERIMETERS.

A MINIMUM OF 60mm SEPARATION BETWEEN FIRE DAMPER AND ADJACENT WALL, FLOOR, OR CEILING & 60mm BETWEEN SINGLE SECTION DAMPERS.

GREEN COLOURED ITEMS MUST BE STEEL AND ARE SUPPLIED BY OTHERS. TESTED EXAMPLE SHOWN, HOWEVER CONSTRUCTION CAN DEVIATE TO A FIRE-SAFE DESIGN PROVIDED APPROVAL FROM A STRUCTURAL ENGINEER HAS BEEN ACQUIRED.

TESTED INSTALLATION METHOD SHOWN. DIFFERING INSTALLATION METHODS TO THIS, MUST BE ACCEPTED BY THE BUILDING CONTROL AUTHORITY (BCA) BEFORE PROCEEDING. THEY WILL NEED TO REFER TO THIS DOCUMENT AND ASSOCIATED I, O & M IN ORDER TO CONSIDER APPROVAL.

Damper size ϕ 100mm to ϕ 315mm

BSB FD-C



SCAN ME
I,O&M

CE DoP-FD-C-06

TESTED TO EN1366-2
CLASSIFIED TO EN13501-3

© THE CONTENT OF THIS DRAWING
MUST NOT BE REPRODUCED IN
WHOLE OR IN PART WITHOUT THE
EXPRESS WRITTEN PERMISSION OF
BSB ENGINEERING SERVICES LTD.



www.bsb-dampers.co.uk

INSTALLATION METHOD

FD-C MASONRY WALL / BATT

PLEASE REFER TO INSTALLATION, OPERATING AND MAINTENANCE DOCUMENT FOR DETAILED INFORMATION.
I, O & M AVAILABLE FROM QR CODE IN FOOTER.

FD-C M8-r3

USE BREAK-AWAY JOINTS (ALUMINIUM RIVETS) ON CONNECTING DUCTWORK.
CONNECTING DUCTWORK AND FIRE BATT HAVE BEEN OMITTED FOR CLARITY.
DAMPER INCLUDES ABLATIVE BATT PENETRATION SEAL.

VIEW A

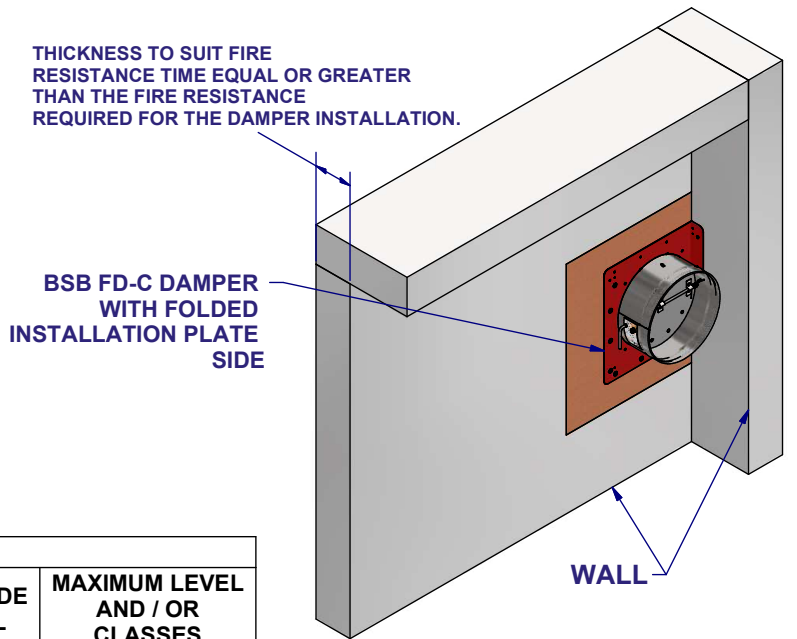
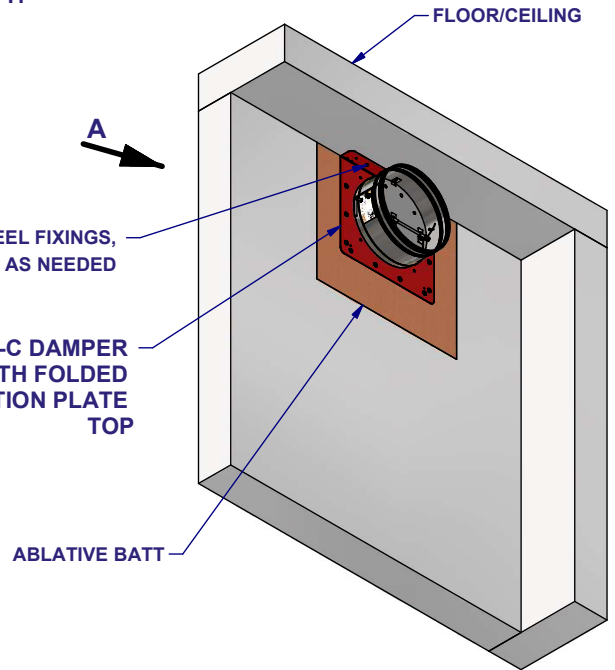
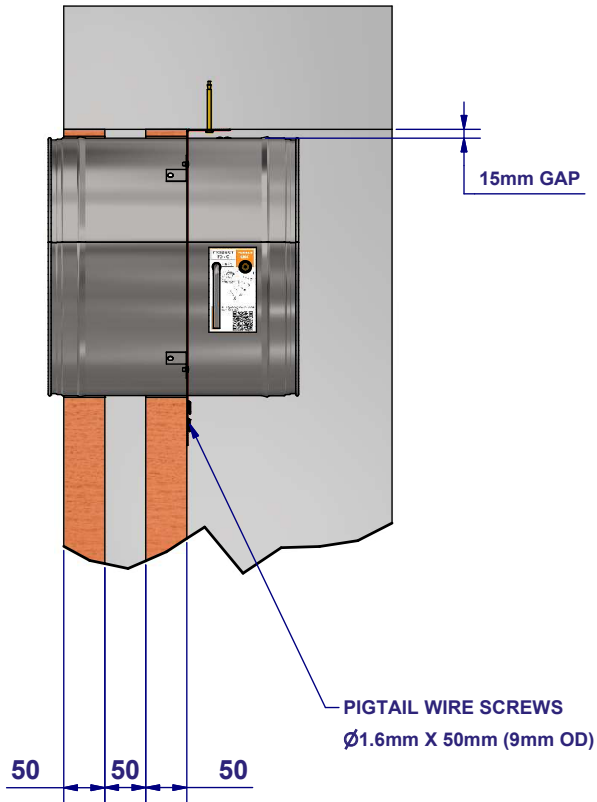

CLASSIFICATION		
MINIMUM CONSTRUCTION	CASE / BLADE MATERIAL	MAXIMUM LEVEL AND / OR CLASSES
150mm Thick Masonry Density 650kg/m ³ 2 x Layers of 50mm Ablative Coated Batt Density 140kg/m ³	Galvanised Steel	E 120 (ve i↔o) S

ALL FIXINGS HOLES ARE TO BE USED TO SECURE THE DAMPER TO THE ABLATIVE BATT/ WALL/CEILING.
DAMPER MAY BE INSTALLED WITH HANDLE IN ANY ORIENTATION.
IT IS ACCEPTABLE TO INSTALL WITH A CUT DOWN PLATE AND 40 X 40 X 2mm MILD STEEL ANGLE, CONTACT BSB FOR FURTHER DETAILS.
A MINIMUM OF 10mm SEPARATION BETWEEN FIRE DAMPER AND ADJACENT WALL, FLOOR, OR CEILING & 60mm BETWEEN SINGLE SECTION DAMPERS.

TESTED INSTALLATION METHOD SHOWN. DIFFERING INSTALLATION METHODS TO THIS, MUST BE ACCEPTED BY THE BUILDING CONTROL AUTHORITY (BCA) BEFORE PROCEEDING. THEY WILL NEED TO REFER TO THIS DOCUMENT AND ASSOCIATED I, O & M IN ORDER TO CONSIDER APPROVAL.

Damper size Ø100mm to Ø315mm

BSB FD-C



SCAN ME
I,O&M

CE DoP-FD-C-06

TESTED TO EN1366-2
CLASSIFIED TO EN13501-3

© THE CONTENT OF THIS DRAWING
MUST NOT BE REPRODUCED IN
WHOLE OR IN PART WITHOUT THE
EXPRESS WRITTEN PERMISSION OF
BSB ENGINEERING SERVICES LTD.



www.bsb-dampers.co.uk

INSTALLATION METHOD

FD-C DRY WALL

A brand of
MAICO

A brand of
MAICO

PLEASE REFER TO INSTALLATION, OPERATING AND MAINTENANCE DOCUMENT FOR DETAILED INFORMATION.
I, O & M AVAILABLE FROM QR CODE IN FOOTER.
USE BREAK-AWAY JOINTS (ALUMINIUM RIVETS) ON CONNECTING DUCTWORK.
CONNECTING DUCTWORK HAS BEEN OMITTED FOR CLARITY.

FD-C M9-r2

INSTALLATION METHOD	
SHEET	METHOD
1	SINGLE SKIN
2	DOUBLE SKIN
3	WALL + ADJACENT STRUCTURE

VIEW A

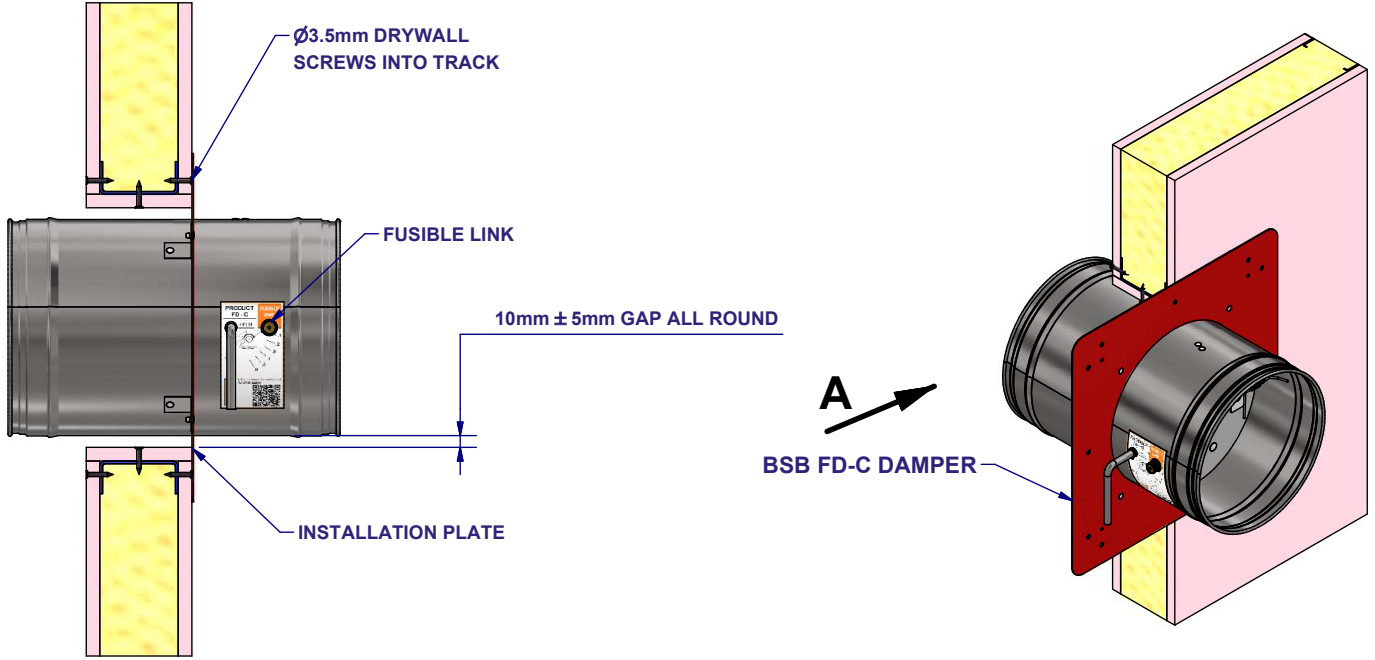

THE DAMPER IS CLASSIFIED TO BE INSTALLED IN EI 30 AND EI 60 SYMMETRICAL WALLS, WITH AND WITHOUT ACOUSTIC INSULATION.

THE SUPPORTING CONSTRUCTION MUST BE OF THE SAME TYPE WITH A FIRE RESISTANCE EQUAL TO EI 30 OR GREATER THAN THAT OF THE SUPPORTING CONSTRUCTION USED IN THE TEST (THICKER, DENSER, MORE LAYERS OF BOARD, AS APPROPRIATE).

SEE NOTE ①

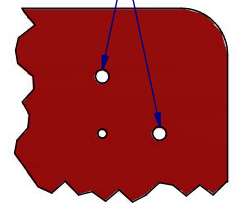

CLASSIFICATION		
MINIMUM CONSTRUCTION	CASE / BLADE MATERIAL	MAXIMUM LEVEL AND / OR CLASSES
Group A 50mm Steel Stud 1 Layer of 12.5mm Type F Board Each Side (EI 30 Fire Resistance)	Galvanised Steel	E 60 (ve i↔o) S

① ONLY ONE FIXING IS REQUIRED PER CORNER. ALL INTERMEDIATE FIXING HOLES ARE TO BE USED.
ALL FIXING SCREWS SHOULD BE SECURELY SCREWED TO THE TRACK LINING THE OPENING.
THE OPENING IN THE WALL MUST BE LINED.
THERE IS NO NEED TO FILL THE OPENING VOID.
DAMPER MAY BE INSTALLED WITH HANDLE IN ANY ORIENTATION.

A MINIMUM OF 75mm SEPARATION BETWEEN FIRE DAMPER AND ADJACENT WALL, FLOOR, OR CEILING & 200mm BETWEEN SINGLE SECTION DAMPERS.

TESTED INSTALLATION METHOD SHOWN. DIFFERING INSTALLATION METHODS TO THIS, MUST BE ACCEPTED BY THE BUILDING CONTROL AUTHORITY (BCA) BEFORE PROCEEDING. THEY WILL NEED TO REFER TO THIS DOCUMENT AND ASSOCIATED I, O & M IN ORDER TO CONSIDER APPROVAL.

Damper size ϕ 100mm to ϕ 315mm

BSB FD-C

CE DoP-FD-C-06

www.bsb-dampers.co.uk



TESTED TO EN1366-2
CLASSIFIED TO EN13501-3

© THE CONTENT OF THIS DRAWING
MUST NOT BE REPRODUCED IN
WHOLE OR IN PART WITHOUT THE
EXPRESS WRITTEN PERMISSION OF
BSB ENGINEERING SERVICES LTD.



ECN 302

INSTALLATION METHOD

FD-C DRY WALL

PLEASE REFER TO INSTALLATION, OPERATING AND MAINTENANCE DOCUMENT FOR DETAILED INFORMATION.
 I, O & M AVAILABLE FROM QR CODE IN FOOTER.
 USE BREAK-AWAY JOINTS (ALUMINIUM RIVETS) ON CONNECTING DUCTWORK.
 CONNECTING DUCTWORK HAS BEEN OMITTED FOR CLARITY.

FD-C M9-r2

INSTALLATION METHOD	
SHEET	METHOD
1	SINGLE SKIN
2	DOUBLE SKIN
3	WALL + ADJACENT STRUCTURE

VIEW A

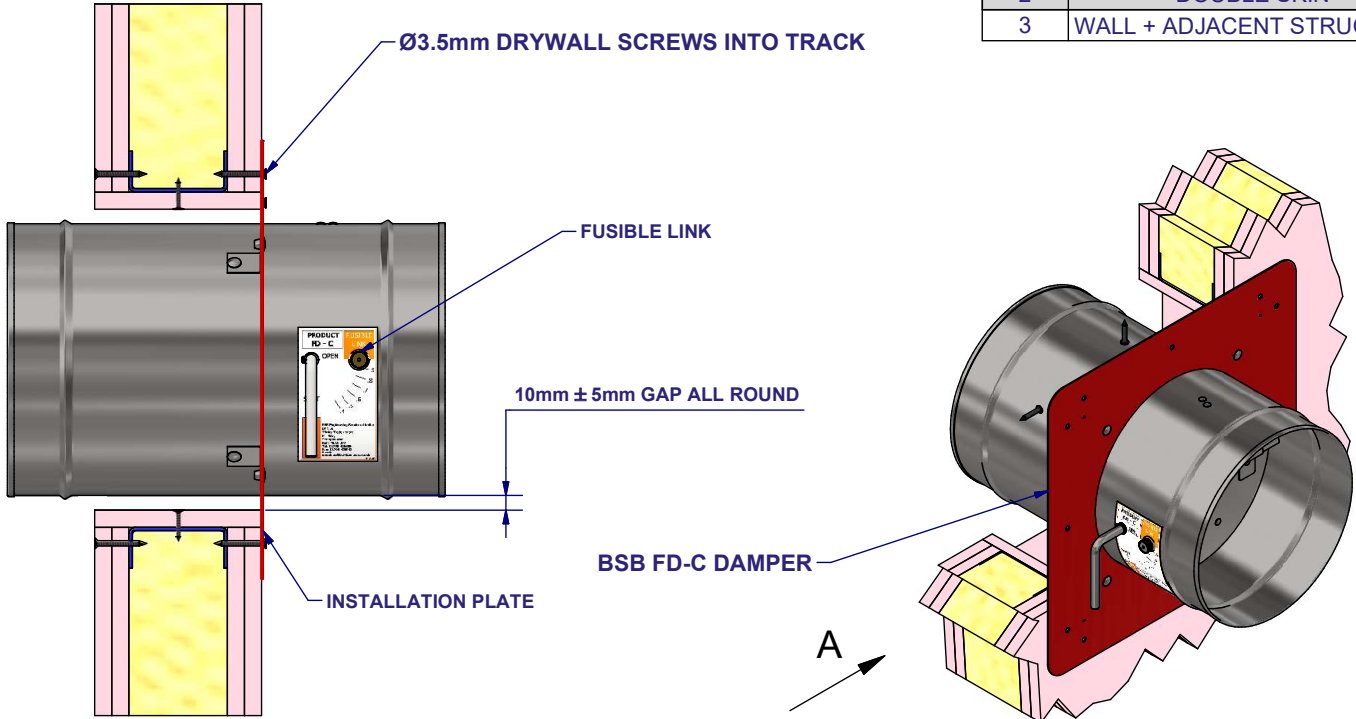

THE DAMPER IS CLASSIFIED TO BE INSTALLED IN EI 90 AND EI 120 SYMMETRICAL WALLS, WITH AND WITHOUT ACOUSTIC INSULATION.

THE SUPPORTING CONSTRUCTION MUST BE OF THE SAME TYPE WITH A FIRE RESISTANCE EQUAL TO EI 90 OR GREATER THAN THAT OF THE SUPPORTING CONSTRUCTION USED IN THE TEST (THICKER, DENSER, MORE LAYERS OF BOARD, AS APPROPRIATE).

CLASSIFICATION		
MINIMUM CONSTRUCTION	BLADE MATERIAL	MAXIMUM LEVEL AND / OR CLASSES
Group B 70mm Steel Stud 2 Layers of 12.5mm Type F Board Each Side (EI 90 Fire Resistance)	Galvanised Steel	E 90 (ve i↔o) S
Group B 70mm Steel Stud 2 Layers of 12.5mm Type F Board Each Side (EI 90 Fire Resistance)	430 Stainless Steel	E 60 (ve i↔o) S*

* For reduced case length option, use 430 stainless steel classification.

① ONLY ONE FIXING IS REQUIRED PER CORNER. ALL INTERMEDIATE FIXING HOLES ARE TO BE USED. ALL FIXING SCREWS SHOULD BE SECURELY SCREWED TO THE TRACK LINING THE OPENING. THE OPENING IN THE WALL MUST BE LINED. THERE IS NO NEED TO FILL THE OPENING VOID. DAMPER MAY BE INSTALLED WITH HANDLE IN ANY ORIENTATION.

A MINIMUM OF 60mm SEPARATION BETWEEN FIRE DAMPER AND ADJACENT WALL, FLOOR, OR CEILING & 60mm BETWEEN SINGLE SECTION DAMPERS.

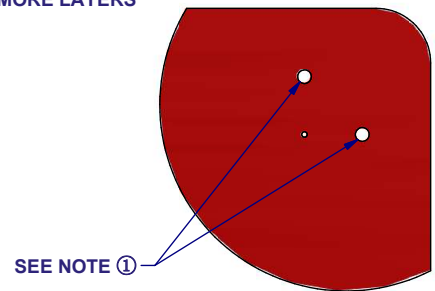

ECN 302

TESTED INSTALLATION METHOD SHOWN. DIFFERING INSTALLATION METHODS TO THIS, MUST BE ACCEPTED BY THE BUILDING CONTROL AUTHORITY (BCA) BEFORE PROCEEDING. THEY WILL NEED TO REFER TO THIS DOCUMENT AND ASSOCIATED I, O & M IN ORDER TO CONSIDER APPROVAL.

Damper size ϕ 100mm to ϕ 315mm

BSB FD-C



SCAN ME
I,O&M

CE DoP-FD-C-06

TESTED TO EN1366-2
CLASSIFIED TO EN13501-3

© THE CONTENT OF THIS DRAWING MUST NOT BE REPRODUCED IN WHOLE OR IN PART WITHOUT THE EXPRESS WRITTEN PERMISSION OF BSB ENGINEERING SERVICES LTD.



www.bsb-dampers.co.uk

INSTALLATION METHOD

FD-C DRY WALL

PLEASE REFER TO INSTALLATION, OPERATING AND MAINTENANCE DOCUMENT FOR DETAILED INFORMATION.
 I, O & M AVAILABLE FROM QR CODE IN FOOTER.
 USE BREAK-AWAY JOINTS (ALUMINIUM RIVETS) ON CONNECTING DUCTWORK.
 CONNECTING DUCTWORK HAS BEEN OMITTED FOR CLARITY.

FD-C M9-r2

INSTALLATION METHOD	
SHEET	METHOD
1	SINGLE SKIN
2	DOUBLE SKIN
3	WALL + ADJACENT STRUCTURE

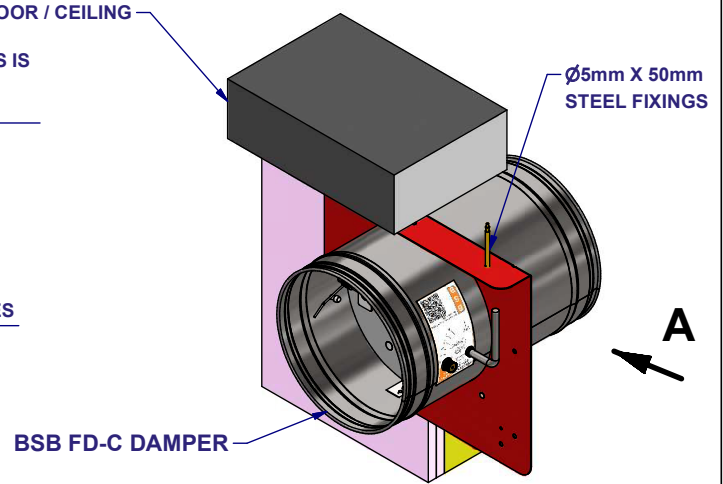
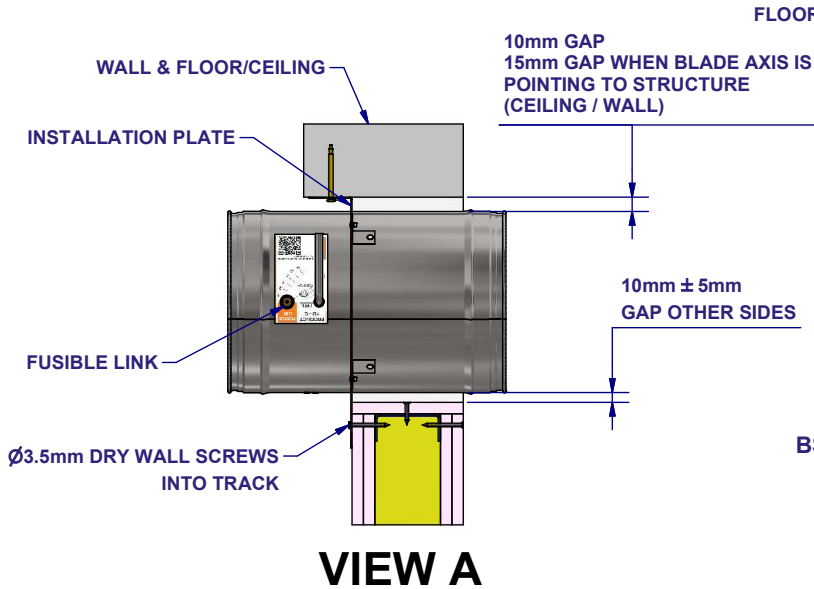

THE DAMPER IS CLASSIFIED TO BE INSTALLED IN EI 90 AND EI 120 SYMMETRICAL WALLS, WITH AND WITHOUT ACOUSTIC INSULATION.

THE SUPPORTING CONSTRUCTION MUST BE OF THE SAME TYPE WITH A FIRE RESISTANCE EQUAL TO EI 90 OR GREATER THAN THAT OF THE SUPPORTING CONSTRUCTION USED IN THE TEST (THICKER, DENSER, MORE LAYERS OF BOARD, AS APPROPRIATE).

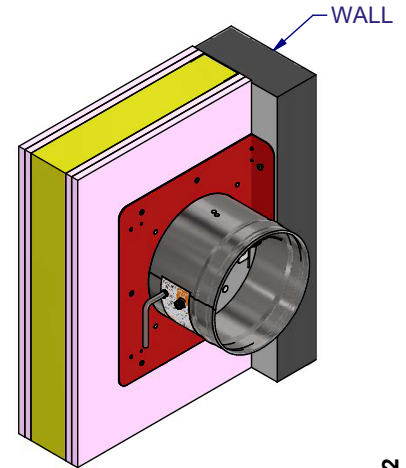

CLASSIFICATION		
MINIMUM CONSTRUCTION	BLADE MATERIAL	MAXIMUM LEVEL AND / OR CLASSES
Group B 70mm Steel Stud 2 Layers of 12.5mm Type F Board Each Side (EI 90 Fire Resistance)	Galvanised Steel	E 120 (ve i↔o) S
Group B 70mm Steel Stud 2 Layers of 12.5mm Type F Board Each Side (EI 90 Fire Resistance)	430 Stainless Steel	E 60 (ve i↔o) S*

* For reduced case length option, use 430 stainless steel classification.

① ONLY ONE FIXING IS REQUIRED PER CORNER. ALL INTERMEDIATE FIXING HOLES ARE TO BE USED. ALL FIXING SCREWS SHOULD BE SECURELY SCREWED TO THE TRACK LINING THE OPENING. THE OPENING IN THE WALL MUST BE LINED. THERE IS NO NEED TO FILL THE OPENING VOID. DAMPER MAY BE INSTALLED WITH HANDLE IN ANY ORIENTATION.

A MINIMUM OF 10mm SEPARATION BETWEEN FIRE DAMPER AND ADJACENT WALL, FLOOR, OR CEILING & 60mm BETWEEN SINGLE SECTION DAMPERS.

TESTED INSTALLATION METHOD SHOWN. DIFFERING INSTALLATION METHODS TO THIS, MUST BE ACCEPTED BY THE BUILDING CONTROL AUTHORITY (BCA) BEFORE PROCEEDING. THEY WILL NEED TO REFER TO THIS DOCUMENT AND ASSOCIATED I, O & M IN ORDER TO CONSIDER APPROVAL.

SEE NOTE ①

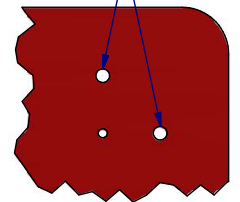

ECN 302

Damper size Ø100mm to Ø315mm

BSB FD-C



I,O&M

www.bsb-dampers.co.uk

CE DoP-FD-C-06

TESTED TO EN1366-2
CLASSIFIED TO EN13501-3

© THE CONTENT OF THIS DRAWING MUST NOT BE REPRODUCED IN WHOLE OR IN PART WITHOUT THE EXPRESS WRITTEN PERMISSION OF BSB ENGINEERING SERVICES LTD.



INSTALLATION METHOD FD-C MASONRY WALL

PLEASE REFER TO INSTALLATION, OPERATING AND MAINTENANCE DOCUMENT FOR DETAILED INFORMATION.

FD-C M10-r2

I, O & M AVAILABLE FROM QR CODE IN FOOTER.

USE BREAK-AWAY JOINTS (ALUMINIUM RIVETS) ON CONNECTING DUCTWORK.
CONNECTING DUCTWORK HAS BEEN OMITTED FOR CLARITY.

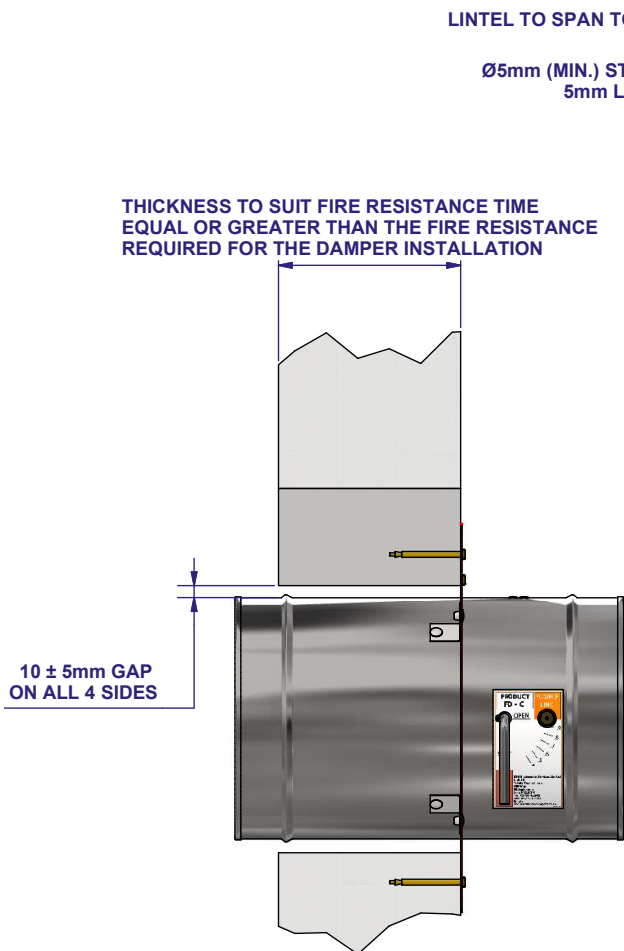

VIEW A

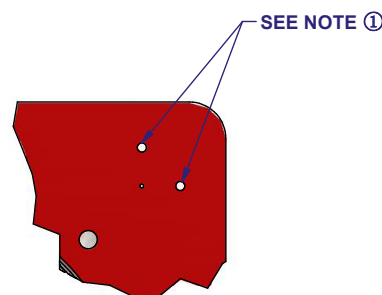
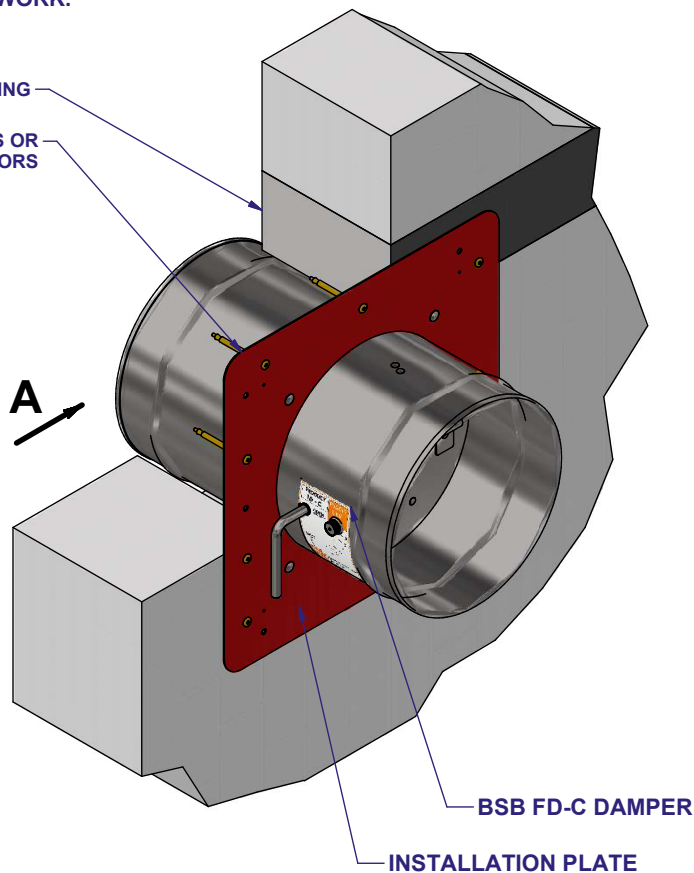

CLASSIFICATION		
MINIMUM CONSTRUCTION	BLADE MATERIAL	MAXIMUM LEVEL AND / OR CLASSES
150mm Thick Masonry Density 650kg/m ³	Galvanised Steel	E 120 (ve i↔o) S
150mm Thick Masonry Density 650kg/m ³	430 Stainless Steel	E 120 (ve i↔o) S*

* For reduced case length option, use 430 stainless steel classification.

① ONLY ONE FIXING IS REQUIRED PER CORNER. ALL INTERMEDIATE FIXING HOLES ARE TO BE USED. THERE IS NO NEED TO FILL THE OPENING VOID.

A MINIMUM OF 60mm SEPARATION BETWEEN FIRE DAMPER AND ADJACENT WALL, FLOOR, OR CEILING & 60mm BETWEEN SINGLE SECTION DAMPERS.

TESTED INSTALLATION METHOD SHOWN. DIFFERING INSTALLATION METHODS TO THIS, MUST BE ACCEPTED BY THE BUILDING CONTROL AUTHORITY (BCA) BEFORE PROCEEDING. THEY WILL NEED TO REFER TO THIS DOCUMENT AND ASSOCIATED I, O & M IN ORDER TO CONSIDER APPROVAL.

Damper size ϕ 100mm to ϕ 315mm

BSB FD-C



SCAN ME
I,O&M

CE DoP-FD-C-06

TESTED TO EN1366-2
CLASSIFIED TO EN13501-3

© THE CONTENT OF THIS DRAWING MUST NOT BE REPRODUCED IN WHOLE OR IN PART WITHOUT THE EXPRESS WRITTEN PERMISSION OF BSB ENGINEERING SERVICES LTD.



www.bsb-dampers.co.uk

INSTALLATION METHOD FD-C MASONRY FLOOR

PLEASE REFER TO INSTALLATION, OPERATING AND MAINTENANCE DOCUMENT FOR DETAILED INFORMATION.

FD-C M11-r2

I, O & M AVAILABLE FROM QR CODE IN FOOTER.

USE BREAK-AWAY JOINTS (ALUMINIUM RIVETS) ON CONNECTING DUCTWORK.
CONNECTING DUCTWORK HAS BEEN OMITTED FOR CLARITY.

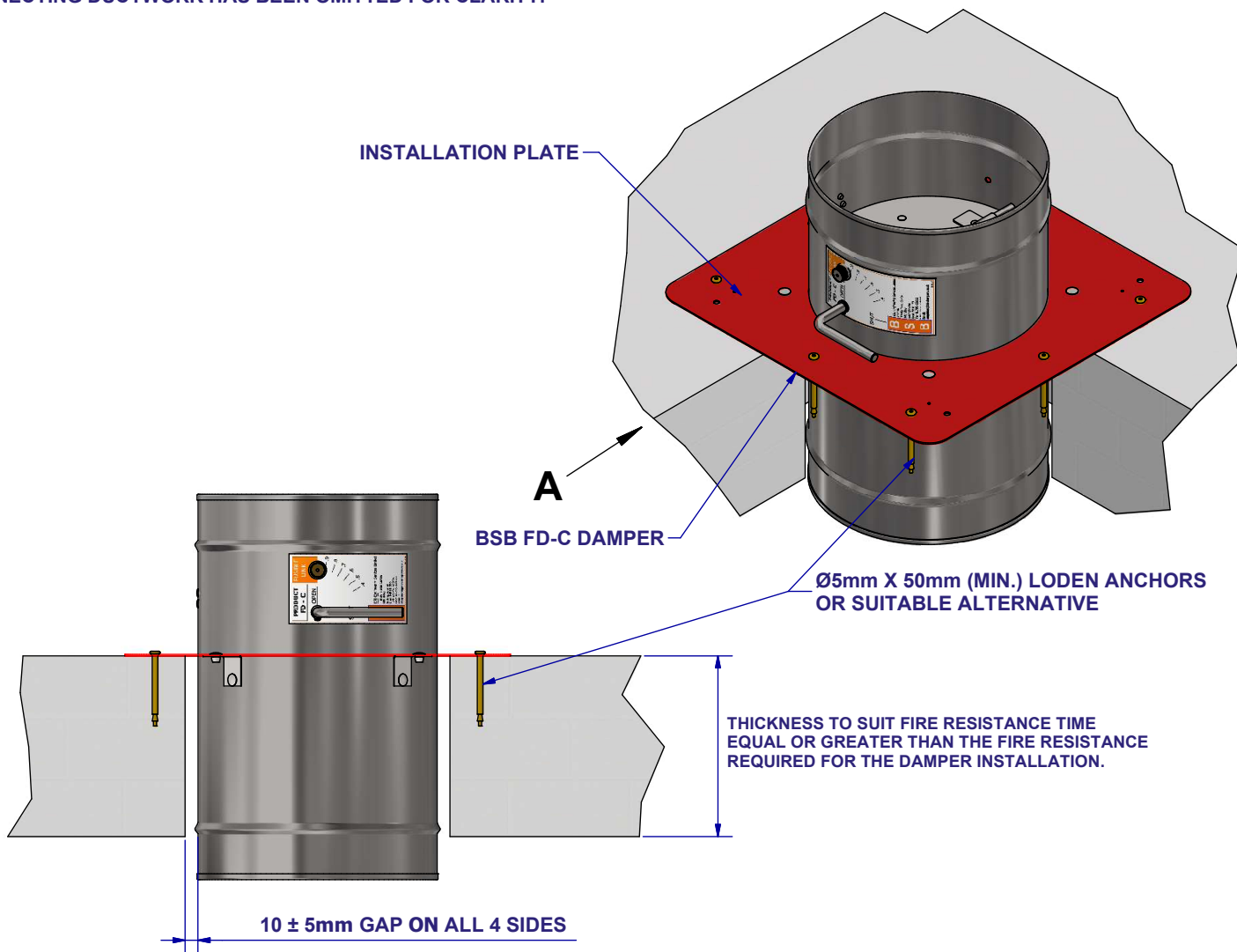

VIEW A

CLASSIFICATION		
MINIMUM CONSTRUCTION	CASE / BLADE MATERIAL	MAXIMUM LEVEL AND / OR CLASSES
150mm Thick Masonry Density 580kg/m ³	Galvanised Steel	E 120 (ho i←o) S

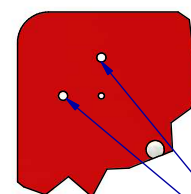

SEE NOTE ①

① ONLY ONE FIXING IS REQUIRED PER CORNER. ALL INTERMEDIATE FIXING HOLES ARE TO BE USED. THERE IS NO NEED TO FILL THE OPENING VOID.

A MINIMUM OF 60mm SEPARATION BETWEEN FIRE DAMPER AND ADJACENT WALL, FLOOR, OR CEILING & 60mm BETWEEN SINGLE SECTION DAMPERS.

TESTED INSTALLATION METHOD SHOWN. DIFFERING INSTALLATION METHODS TO THIS, MUST BE ACCEPTED BY THE BUILDING CONTROL AUTHORITY (BCA) BEFORE PROCEEDING. THEY WILL NEED TO REFER TO THIS DOCUMENT AND ASSOCIATED I, O & M IN ORDER TO CONSIDER APPROVAL.

Damper size \varnothing 100mm to \varnothing 315mm

BSB FD-C



SCAN ME
I,O&M

CE DoP-FD-C-06

TESTED TO EN1366-2
CLASSIFIED TO EN13501-3

© THE CONTENT OF THIS DRAWING MUST NOT BE REPRODUCED IN WHOLE OR IN PART WITHOUT THE EXPRESS WRITTEN PERMISSION OF BSB ENGINEERING SERVICES LTD.



www.bsb-dampers.co.uk

INSTALLATION METHOD FD-C-FC FIRE CURTAIN FRAME

PLEASE REFER TO INSTALLATION, OPERATING AND MAINTENANCE DOCUMENT FOR DETAILED INFORMATION. FLEXIBLE FIRE CURTAIN TO BE INSTALLED TO FIREFLY® INSTALLATION GUIDE. I,O & M AVAILABLE FROM QR CODE IN FOOTER
USE BREAK-AWAY JOINTS (ALUMINIUM RIVETS) ON CONNECTING DUCTWORK.
CONNECTING DUCTWORK HAS BEEN OMITTED FOR CLARITY.

FD-C M14-r0

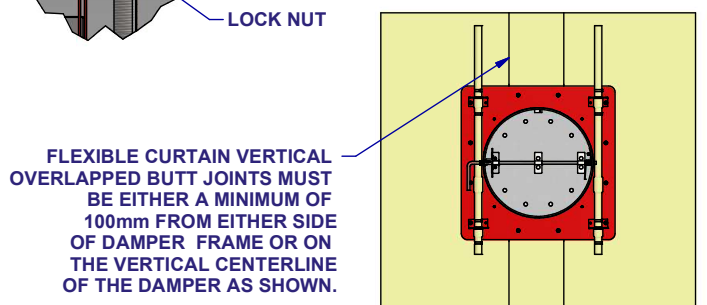
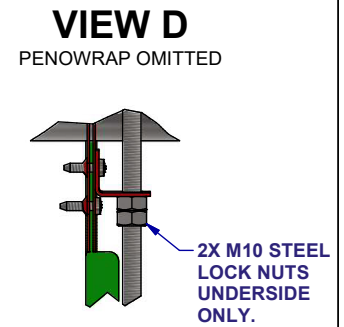
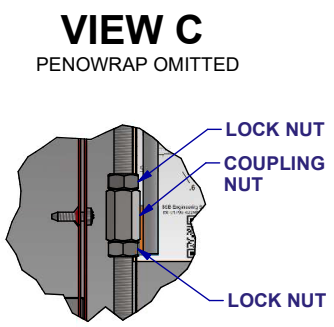
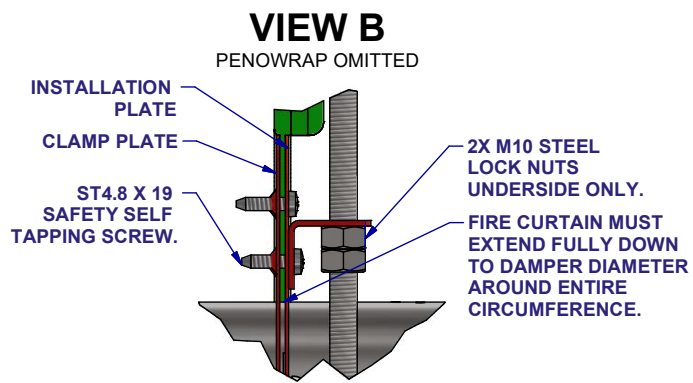
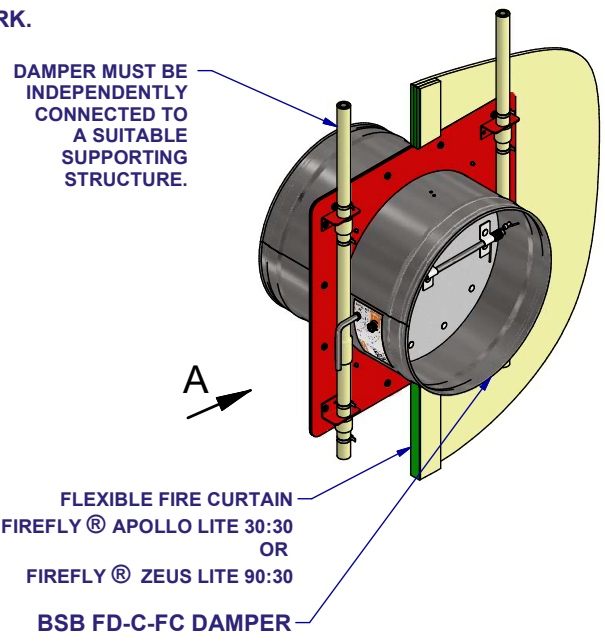
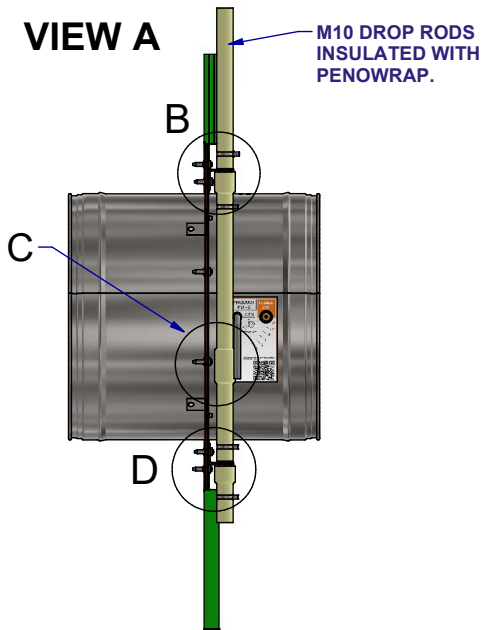

CLASSIFICATION		
MINIMUM CONSTRUCTION	CASE / BLADE MATERIAL	MAXIMUM LEVEL AND / OR CLASSES
Apollo Lite 30:30 Minimum Thickness 6mm	Galvanised Steel	E 60 (ve i↔o) S
Zeus Lite 90:30 Minimum Thickness 6mm	Galvanised Steel	E 60 (ve i↔o) S

ALL FIXING SCREWS MUST BE SECURELY FIXED TO CLAMP PLATE.
IT IS ACCEPTABLE TO USE A COUPLING NUT + LOCK NUT SHOWN IN VIEW C, POSITIONED ANYWHERE BETWEEN CLEATS.
A MINIMUM SEPARATION OF 75mm BETWEEN FIRE DAMPER AND ADJACENT WALL, FLOOR OR CEILING & 200mm BETWEEN DAMPERS.

TESTED INSTALLATION METHOD SHOWN. DIFFERING INSTALLATION METHODS TO THIS, MUST BE ACCEPTED BY THE BUILDING CONTROL AUTHORITY (BCA) BEFORE PROCEEDING. THEY WILL NEED TO REFER TO THIS DOCUMENT AND ASSOCIATED I,O & M IN ORDER TO CONSIDER APPROVAL.

Damper size \varnothing 100mm to \varnothing 315mm		CE DoP-FD-C-06	
BSB FD-C-FC	 SCAN ME I,O&M		
www.bsb-dampers.co.uk		TESTED TO EN1366-2 CLASSIFIED TO EN13501-3 CE MARKING CoCoP PENDING	© THE CONTENT OF THIS DRAWING MUST NOT BE REPRODUCED IN WHOLE OR IN PART WITHOUT THE EXPRESS WRITTEN PERMISSION OF BSB ENGINEERING SERVICES LTD.

ECN 307

FD-C Series

Single Blade Circular Fire Dampers - Ordering Codes



FD-C Externally Resettable Circular Single Blade Damper

FD-C 200 G MS

FD-C-FC Fire Curtain Frame

Diameter: _____

Blade Material _____

G Galvanised Mild Steel

S 430 Grade Stainless Steel

Accessories _____

MS Single Pole Micro Switch

R-CL Rotatable Cleat

Other Air, Fire and Smoke Control Products in the BSB Range:

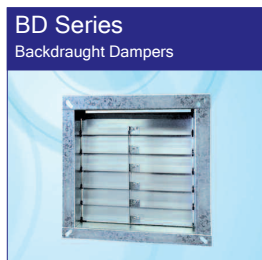
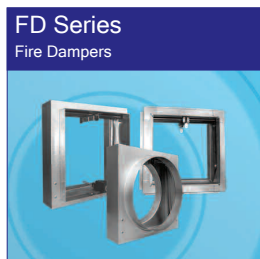

For full details of the complete BSB Product Range, please refer to our individual product brochures, sales office or website.



BSB Engineering Services Limited

Unit 56, Trinity Trade Centre, Mill Way, Sittingbourne, Kent ME10 2PD, UK • Tel: +44 (0)1795 422609

For purchase orders and order related enquiries, please email: orders@bsb-dampers.co.uk

For pricing, technical and general enquiries, please email: enquiries@bsb-dampers.co.uk

A brand of
MAICO

Website: www.bsb-dampers.co.uk • A member of the Maico group

BSB Engineering Services Ltd. reserves the right to modify or withdraw any specification without prior notice that may result from continuous product development. The information contained within this brochure is correct at the time of going to press.

